

FURNITURE LEISURE INC

1.800.213.2401

www.FurnitureLeisure.com
www.PicnicFurniture.com
www.ParkTables.com

www.PoolFurnitureSupply.com
www.PicnicTableSupplier.com
www.UBrace.com

CDG48 - Chippendale Glider [81 lbs]

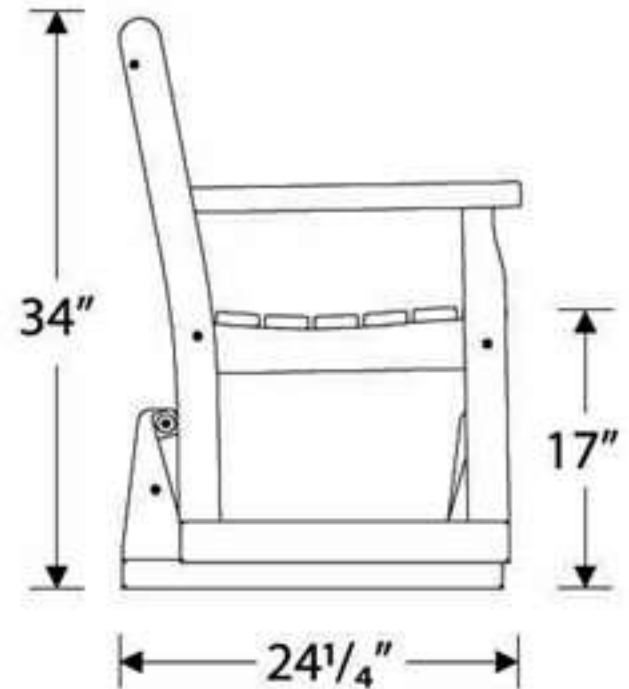
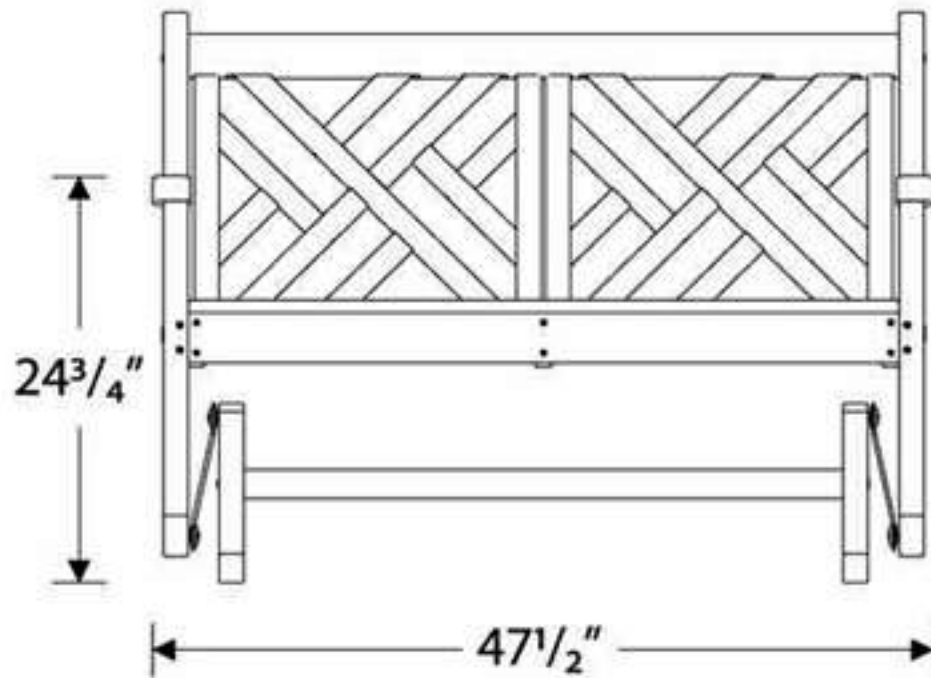

POLYWOOD®

Intelligent Design™

Assembly Instructions Model: CDG48

- (1) Seat
- (1) Back
- (2) Sideframes
- (2) Glider Base Frames
- (2) Glider Cross Brace
- (1) Hardware pack

TOOLS NEEDED

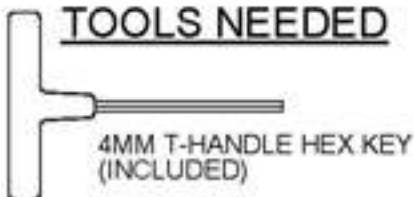

Qty.	Description
8	A - 1/4-20 X 1-1/2 WAFER SHCS FINE THREAD
2	B - 1/4-20 X 2-1/4 WAFER SHCS FINE THREAD
9	C - .27 X 2 1/2 SOCKET WAFER "A"

ASSEMBLY INSTRUCTIONS

*NOTE: ALL FINE THREAD BOLTS (A) AND (B), WILL THREAD INTO EITHER THE TUBE OR AN INSERT NUT. COURSE THREAD SCREWS GO STRAIGHT INTO THE POLY

Step 1

Attach sideframes to seat using (4) 1½" chair bolts (A).
DO NOT TIGHTEN!!

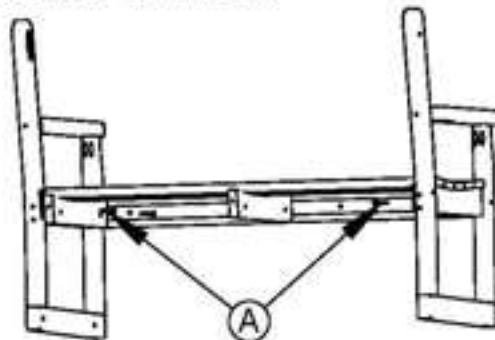

Step 2

- Attach back to sideframes using (2) 2¼" chair bolts (B) into the tube on top and (4) 2½" screws (C) on bottom
- Attach center of the back to the seat using (1) 2½" screw (C)



Step 3

- Tighten the 1½" chair bolts from Step 1

- Attach cross braces to the glider base frames with (4) 2½" screws (C)

Step 4

- Attach glider base to bench with (4) 1½" chair bolts (A).

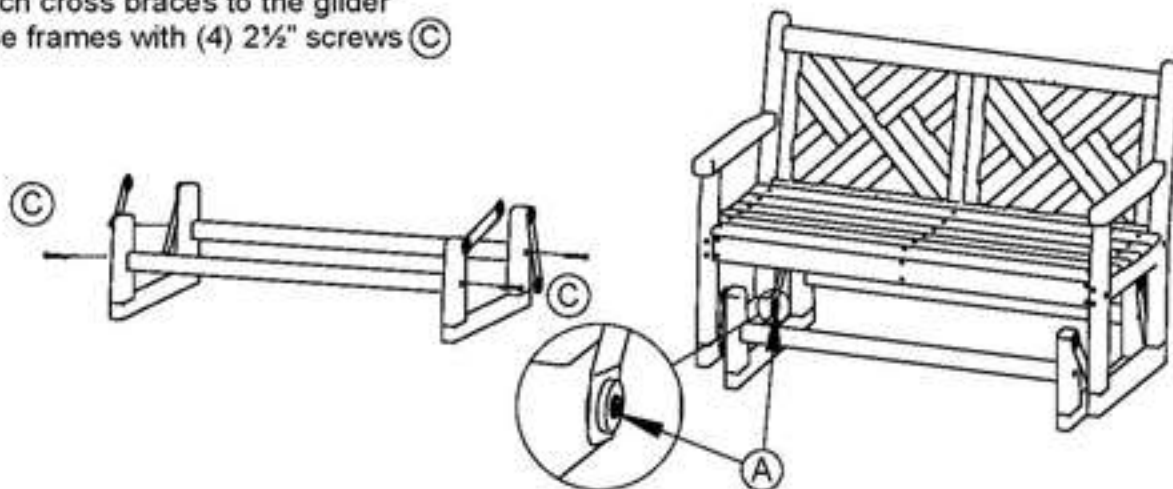

ALL HARDWARE IS COATED STAINLESS STEEL

DETAIL A

10/25/2012

FURNITURE LEISURE INC

1.800.213.2401

www.FurnitureLeisure.com
www.PicnicFurniture.com
www.ParkTables.com

www.PoolFurnitureSupply.com
www.PicnicTableSupplier.com
www.UBrace.com